



KT Series Instruction Sheet

■ Precautions

⚠ DANGER! Caution! Electric Shock!

1. Do not touch the AC terminals while the power is supplied to the controller to prevent an electric shock.
2. Make sure power is disconnected while checking the unit inside.

⚠ WARNING!

This controller is an open-type temperature controller. Make sure to evaluate any dangerous application in which a serious human injury or serious property damage may occur.

1. Always use recommended solder-less terminals : M3.0 Bolt and width is less than 7.2mm and tightening torque is 0.4N.m(4kgf.com).
2. Do not allow dust or foreign objects to fall inside the controller to prevent it from malfunctioning.
3. Never modify or disassemble the controller.
4. Do not connect anything to the "No used" terminals.
5. Make sure all wires are connected to the correct polarity of terminals.
6. Do not install and/or use the controller in places subject to:
 - Dust or corrosive gases and liquid.
 - High humidity and high radiation.
 - Vibration and shock.
 - High voltage and high frequency
7. Must turn power off when wiring and changing a temperature sensor.
8. Be sure to use compensating wires that match the thermocouple types when extending or connecting the thermocouple wires.
9. Please keep the wire as short as possible when wiring a platinum resistance thermometer(RTD) to the controller and please route power wires as far as possible from load wires to prevent interference and induced noise.
10. This controller is an open-type unit and must be placed in an enclosure away from high temperature, humidity, dripping water, corrosive materials, airborne dust and electric shock or vibration.
11. Please make sure power cables and signals from instruments are all installed properly before energizing the controller, otherwise serious damage may occur.
12. Please do not touch the terminals in the controller or try to repair the controller when power is applied to prevent an electric shock.
13. Wait at least one minute after power is disconnected to allow capacitors to discharge, and please do not touch any internal circuit within this period.
14. Do not use acid or alkaline liquids for cleaning. Please use a soft, dry cloth to clean the controller.
15. This instrument is not furnished with a power switch or fuse. Therefore, if a fuse or power switch is required, install the protection close to the instrument. Recommended fuse rating: Rated voltage 250 V, Rated current 1 A. Fuse type : Time-lag fuse

■ Ordering Information

KT - [①] [②] (Economical Type)

- ① Front size 4 : W48 × H48mm 2 : W48 × H96mm 7 : W72 × H72mm
 ② Output Selection 7 : Relay + Voltage for driving SSR

■ Product Selection

Size	Part No.	Output
4896	KT270	Relay + SSR
4848	KT470	Relay + SSR
7272	KT770	Relay + SSR

■ Specification

Input Power	100-240VAC 50/60Hz
Operation Voltage Range	90%-110%, rated voltage
Power Consumption	5VA Maximum
Display Method	7-segment LED : PV in red, SV in green
Sensor Type	Thermocouple : K,E,J,N,S,T,R,B Platinum resistance : PT100
Analog Input	Voltage : 0-20mA, 0-50mV
Display Accuracy	Normal temperature (23°C ± 5°C): (PV ± 0.5% or ± 1°C, select the higher one) ± 1digit Out of normal temperature range : (PV ± 0.5% or ± 2°C, select the higher one) ± 1digit
Control Mode	On/Off Control, PID Control
Control Output	Relay output : 250vac 3A Voltage Pulse output
Sampling Rate	250ms
Vibration Resistance	0.7mm amplitude at 10-55Hz in each 3 directions for 1.5 hours
Ambient Temperature	-10-50°C (with no icing)
Storage Temperature	-12-60°C (with no icing)
Relative Humidity	35-85%RH , Storage : 35-85%RH

■ Part Description

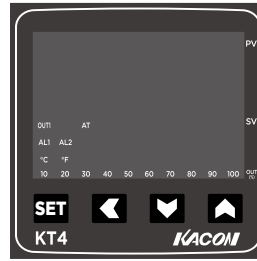

PV	parameter list and the current temperature display
SV	Parameter setting value and control temperature setting display
OUT1	Turn on when the main control output is generated
AT	Turn on when run the Auto-tuning of PID control.
AL1	Turn on when the alarm output is generated
AL2	
°C , °F	Display the Temperature Unit (Celsius, Fahrenheit)
OUT (%)	Display the Percentage of main output value
SET	Move forward for parameter and save the set value.
←	Move digit of character and move backward for parameter.
↑	Increase a number and release the function of control stop.
↓	Decrease a number and set the function of control stop.

■ External Dimension and Panel Cutout

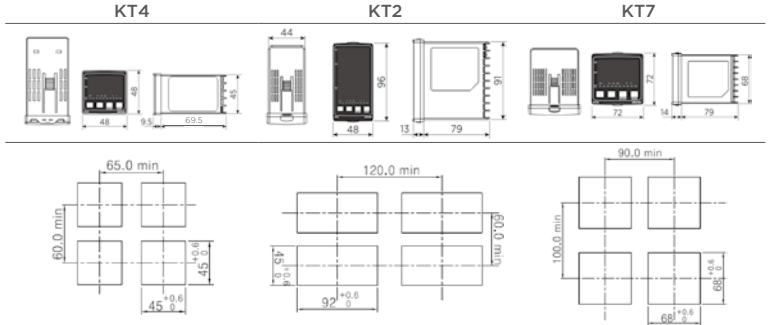

■ Terminal Definition

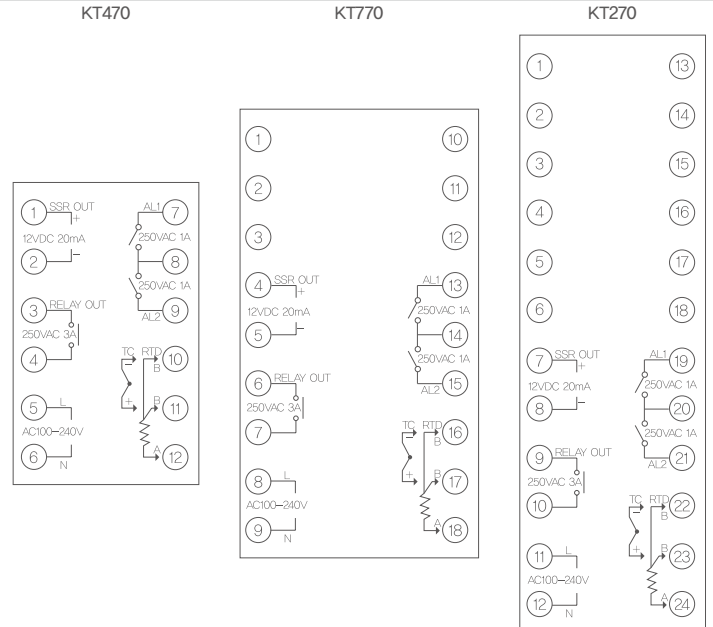

■ Setting mode 1

Press **SET** up to 3 sec for parameter group 1
SET for adjusted parameter save and pass to next parameter.
← key is for return to previous parameter by 3 sec pressing
 If you press **SET** more than 3 sec for initial display.

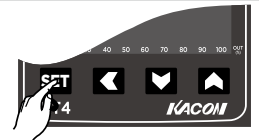

Symbol	Name	Range	#	Description
At	Autotuning	NO or YES	NO	YES: Autotuning on NO: Autotuning off
AL1	Alarm 1	-1999-9999	0	Set the alarm value for alarm 1. Alarm differential gap=AH1
AL2	Alarm 2	-1999-9999	0	Set the alarm value for alarm 2 Alarm differential gap=AH2
Sc	PV bias	-199-199	0	Sensor correction is made by adding bias value to measured value(PV).
P	Proportional band	0.0-200.0	20	Proportional band in PID with unit for OUT1 P=0.0, ON/OFF control Please set PI=2.0 when analog input.
HYS	Control Hysteresis	0-999	1.0	Control out differential gap=HYS Only for ON/OFF action when P=0.0
I	Integral time	0-3600s	210	Set the time of integral action to eliminate the offset occurring in proportional control.
d	Derivative time	0-3600s	30	Set the time of derivative action to improve control stability by preparing for output changes.
Cyc	Proportioning Cycle	0-999s	20	Proportioning cycle time for PID control
rSt	Proportional reset	-999-200	-5	Proportional reset for overshoot protection when first power on. (Auto setting after autotuning)
LCK	Set data lock	0-2	0	LCK 0 : Allow to modify any parameter and SV LCK 1 : SV Only allow to modify SV and AT. LCK 2 : Not allow to modify any parameter and SV

■ Setting mode 2

Press the key while pressing the SET key for 3 s to PASS, set PASS=0101, then press SET key to parameter group 2



The following parameter symbols are displayed one by one every time the SET key is pressed. After the value be registered, when no parameter setting is required, Press the SET key for 3 s to return the instrument to the normal display.

Symbol	Name	Range	1#	Description
INP1	Main input type select		K	Temperature sensor table reference
dP	Decimal point	0-3	0	Desimal point creation 0,1 : for TC or RTD or analog type 2,3 : Only for Linear analog type input
LSPt	Low setting	-1999-9999	0	Set lower setting limiter Set high setting limiter
USPt	High setting	-1999-9999	400	Lower point of transmission Higher point of transmission
UNIT	Display scale	C,F,A	C	Temperature unit set C : Centigrade F : Fahrenheit A : without scale
PvFt	PV follow-up PV input filter	0-60	55	PV variable-value control, 0-30: for general, 31-60: for enhanced
ANL1	Lowest value of PV display	-199-9999	0	Lowest value display when linear analog inputs, Such as 4-20mA input.
ANH1	Highest value of PV display	-1999-9999	2000	Highest value display when linear analog inputs, Such as 4-20mA input.
ALd1	Alarm1 mode	00-16	10	Select the type of alarm 1 See (**ALARM TYPE TABLE)
AH1	Alarm1 differential gap	0.0-100.0	0.4	Alarm1 differential gap setting
ALd2	Alarm2 mode	00-16	10	Select the type of alarm 2 See (**ALARM TYPE TABLE)
AH2	Alarm2 differential gap	0.0-100.0	0.4	Alarm2 differential gap setting
OUd	Control action	HEAT, COOL	HEAT	HEAT : Reverse action (Heating) COOL : Direct action (Cooling)
OUt	Control output type		rLy	rLy : Relay drive output SSr : SSR relay drive output
SSr	SSR drive output method		Stnd	Stnd : Nomal control CYCL : Cycle control PHAS : Phase control
H-	Power frequency	50, 60	60	50H- : 60H- :
LbAt	LBA monitoring time	0-9999	0	Set the alarm time of the Disconnection alarm.
LbAb	LBA monitoring range	0-9999	0	Set the temperature value of the Disconnection alarm.

■ Setting mode 3

Set PASS = '0202' then press SET key to parameter group 3.



Symbol	Name	Range	1#	Description
d1-2	RUN / STOP	0 or 1	0	D1-K=0 RUN / STOP Disable D1-K=1 RUN / STOP Enable
rEst	Parameter reset	0 or 1	0	Parameter reset to factory value

■ Pasword Mode

Press the SET button along with the **←** button, to enter the password mode. Use the **▲▼** buttons to change the numbers, and press the **←** button to change the cipher numbers.

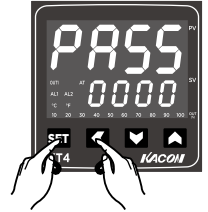

■ Input Sensor Type and Setup

Type '0101' at the password mode to enter the parameter 2 group. The letters 'INP1' will appear at the PV window, while the letter '---K' at the SV window ('---K' is the initial setup value of the K-type thermocouple). Use the **▲▼** buttons to select the proper sensor type, and then press the SET button to save the setup value.

Sensor Classification	Display Form	Snsor Type	Range(°C)
Thermocouple	2	K	1300 °C
	E	E	600 °C
	J	J	800 °C
	N	N	1300 °C
	U	Wu3-Re25	2000 °C
	S	S	1600 °C
	t	T	400 °C
	r	R	1700 °C
	b	B	1800 °C
	Analog	AN4	-
AN3		0-50mV	
AN1		0-20mV	
RTD	Pt	PT100Q	800 °C

■ Parameter Moving



Main Control Temperature Setup

Press one of the front four buttons for 0.5 seconds, and then release the button. The image will flicker, and the status will change to allow the temperature setup. Use the up and down buttons to select the temperature to control, and then press the **SET** button to save it. If no buttons are pressed for approximately 15 seconds at the temperature setup mode, the temperature will be automatically saved, and the blinking will stop.

Temperature Correction

Press the **SET** button for more than 3 seconds to enter the parameter group 1. If the letters 'At' appear at the PV, press the **SET** button three times to enter the 'SC' parameter. The 'SC' value is initially set at '0'. Enter the temperature value to be corrected, and press the **SET** button to save it.

For example, if the actual temperature is 50°C, while the PV displays 48°C, replace the value '0' of the 'SC' with '2'. The actual temperature '50°C' will appear at the PV window.

Heating and Cooling Control

This controller will regulate two temperatures for both heating and cooling. The product is initially set at the heating control. Therefore, go to the parameter group 2, and save either heating (**HEAT**) or cooling (**COOL**) at the control direction setup parameter '**Outd**'.

ON/OFF Control Setup

- The ON/OFF control is designed with a simple control output type. The control output is turned on when the setup value is yet to be reached; otherwise, the control output is turned off when the setup value is reached.
- It can be first distinguished in the parameter group 1, wherein the letters 'RL' are first displayed at the PV window from the PID control mode, while the letter 'SC' is first shown at the ON/OFF control.
- Go to the parameter group 1 via the startup screen. The initial value of the control output type is set at the PID control. Therefore, the letters 'RL', which means auto tuning at the PID control mode, will be displayed at the PV window.
- Use the **SET** buttons to select the parameters. The 'P' parameter, which is the proportional value of the PV window, will be displayed with the initial value '20' at the SV window. Replace '20' with '0', and press the **SET** button to save the changed value. The ON/OFF control setup is complete.

Hysteresis Value Set-up

- In this function, deviations can be applied to the output of the ON/OFF control mode. Once the target control value is reached while in the ON/OFF control, the output may frequently turn on or off to maintain the target value. Deviations can be applied to the output in order to extend the output ON/OFF cycles.
- Go to the parameter group 1, and use the **SET** button to go to the 'HYS' at the PV window. Replace the initial 'HYS' value to '1.0', and press the **SET** button to save it. The Hysteresis value setup is complete.

PID Control Set-up

- The PID control takes a longer time to reach the target value, as compared with the ON/OFF control. Nevertheless, it can achieve the exact and precise control at various setup values.
- The factory setting of this product is set at the PID control mode; however, there are instances when it has been changed to the PID control in the ON/OFF control setup.
- While at the parameter group 1, the symbol 'RL' is first displayed at the PV window if the controller is set at the PID control mode, while the first word appears as 'SC' at the ON/OFF control mode.
- Go to the parameter group 1 via the ON/OFF startup screen. Press the SET button to change the parameters, so that the proportional value 'P' can be displayed at the PV window. Change the '0' value with a higher number at the SV window and save it.
- The PID control needs to set parameters consisted of a number of comprehensive equations. Such equations are too difficult to calculate immediately. Therefore, the automatic formula calculation function, which is called the auto tuning, is applied.

Filtering the Current Temperature Input Value

- Rapid changes in the temperature value may trigger frequent changes to the PV display value.
- Such will affect the control operation volume, and make it difficult to achieve a stable control. However, the display value of the current temperature can be stabilized by applying the current temperature filter '**P:FE**' in the parameter group 1.
- Increase the filter value to slow down the changing speed of the input display value, and to steadily display the current value.

Proportional Value Reset

- If the proportional values are applied to the temperature control (PID/P), a certain deviation may occur even when control has been stabilized depending on the heater capacity and/or the space area.
- The proportional value reset '**r:SE**' function in the parameter group 1 enables the correction of the steady-state deviation (OFFSET).
- For an automatic setup, execute the auto tuning '**RL**' at the PID control mode.

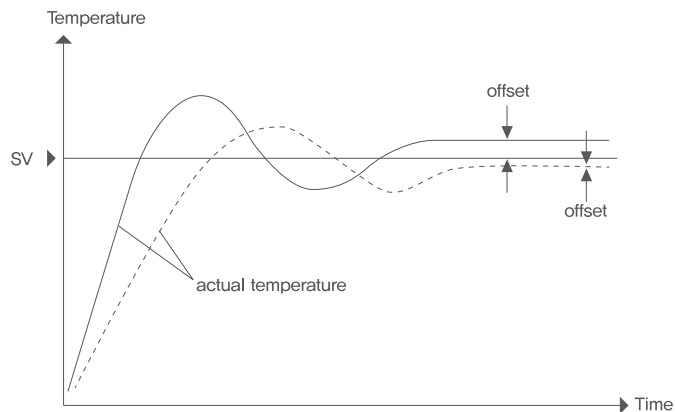

OFFSET: It normally means a dislocation or deviation. In temperature control, the term refers to the degree of difference between the setup value (SV) at a state where the operation value is stabilized, and the current controlled temperature value (PV).

Auto Tuning

- This function automatically sets the proportional (P), integral (I), and differential (D) values at the PID control mode.
- After selecting the PID mode in the control setting of the product, go to the parameter group 1, and check if the letters 'RL' appear at the PV window, and 'NO' at the SV window, respectively. Use the direction buttons to change from 'NO' to 'YES', and save it by pressing the **SET** button. The auto tuning will start to repeat a number of over and under shootings around the target value to complete the process.
- The progress of the auto tuning can be checked through the blinking of the 'RL' lamp at the display window.

Relay and SSR Outputs

- The CARCON Temperature Controller KT Series is built in with the relay output and the SSR output contacts.
- The parameter setup helps facilitate changes to the main output method.
- Go to the parameter group 2, select the relay '**RLY**' or the SSR '**SSR**', and save it as '**Out**' at the output method setup parameter.
- In the case of 'SSR', the output methods consisted of three methods, which can be selected by the user depending on the control situation.

SSR Output Method

- Select the output method of the controller with SSR to activate the SSR output type parameter '**SSr**' in the parameter group 2.
- The SSR output type has a total of three kinds, which can be selected by the user depending on the situation.
 - Normal Control (Stnd)**
This function operates in the same way as the normal relay output in accordance with the ON/OFF or the PID controls.
 - Cycle Control (CYCL)**
This function controls the output volume by adjusting the output numbers during a certain cycle, and the temperature will repeatedly flicker ON/OFF according to the output ratio. The output ratio can be observed through the (%) display lamp. The blinking number decreases when the current value approaches the target value, while the blinking number increases as the current value gets far from the target value. Depending on the case, if the output ratio becomes higher than the reference point, the OUT lamp will continuously flicker.
 - Status Control (PHAS)**
This function controls the status within a half cycle of the AC power source, and produces a similar effect when using a power controller. However, such function is operative at a random cross SSR only.

Example for Circuit configuration of SSR output

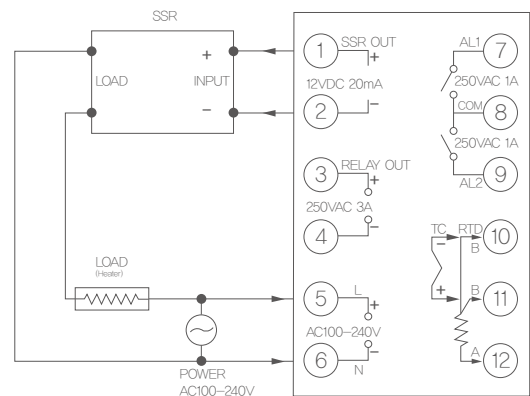

- SSR is set to single-phase, Also applicable to three-phase SSR
- Examples of how to control the heat control for convenience heard.

Example for Circuit configuration of Relay output

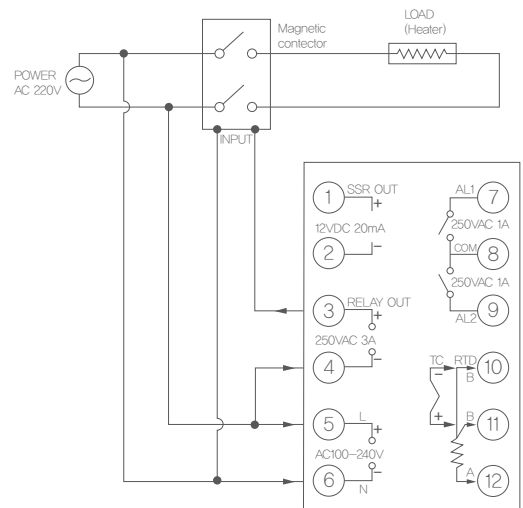

- Set the main power supply is AC220V and example output of the magnetic contactor heard.
- Examples of how to control the heat control for convenience heard.

Alarm mode specification

Operation Type	Set Value	Alarm Type	Specification (Example for alarm 1)
10 or 00		No alarm	
Normal Action	11	High limit Alarm	$AL \geq 0$
		High limit Alarm	$AL < 0$
	12	Low limit Alarm	$AL \geq 0$
		Low limit Alarm	$AL < 0$
	13	High-low limit Alarm	
	14	Band alarm	
Holding Action	01	High limit Alarm	$AL \geq 0$
		High limit Alarm	$AL < 0$
	02	Low limit Alarm	$AL \geq 0$
		Low limit Alarm	$AL < 0$
	03	High-low limit Alarm	
	04	Band alarm	
	05	Absolute high alarm	
	06	Absolute low alarm	
	09	Break loop alarm	

Example of the output of the holding operation

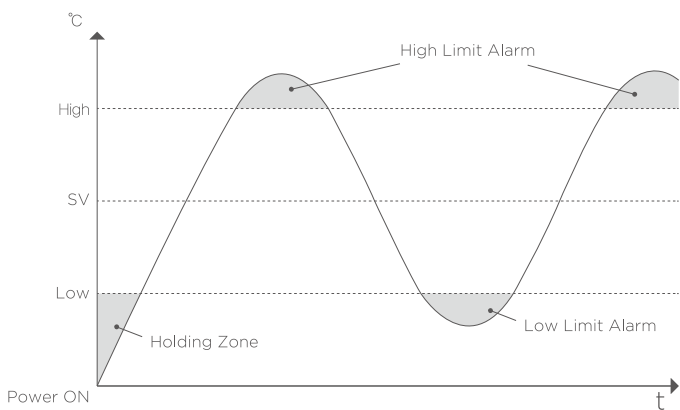

* With holding action : When holding action is ON, the alarm action is suppressed at start-up until the measured value enters the non-alarm range

Alarm (Warning) Set-up

- The output, which can be used as a supplement output other than the main output that controls the temperature, is called an alarm output or warning output.
 - This product consisted of two alarm-relay contacts. Refer to the alarm setup table to produce various types of alarms.
 - Go to the parameter group 2 to select the alarm setup 1 parameter (**RLd1**) at the PV window.
 - The product is initially set to show the value '0' at the SV window, which suggests that there is no alarm. Refer to the alarm setup table to enter the function code to be used, and press the **SET** button to save it.
 - The alarm 2 setup can be established in the same method as the alarm 1. This can be achieved by selecting the alarm 2 parameter (**RLd2**).
 - Once the alarm function is set, the reference value for the output (i.e. the alarm setup value) is required. This setup value determines the time when the output occurs, and may differ depending on the alarms with the deviation value or the absolute value.
 - Go to the parameter group 1, select either AL1 or AL2 at the PW window, enter the appropriate setup value, and save it.
 - Deviation value : This means that the value, as well as the deviated temperature, is based on the main setup temperature value. If the main setup temperature value changes, the value will automatically change the alarm output time accordingly.
- Example) Main setup temperature : 100°C
 Upper deviation limit of the deviated alarm value : 5°C
 Output time : 105°C
- Absolute value : The alarm setup value itself that matches the value at the output time regardless of the main setup temperature value. If the current temperature value matches the setup value, the alarm output will occur. Such values of the alarm output time will not change even though the main setup temperature values have changed.

Alarm for Heater disconnection

- This function determines the heater disconnections depending on the temperature changes during setup.
 - While the main control output runs 100%, an alarm signal will sound when it considers that the heater is abnormally connected, as there are no changes made with the setup temperature (LbAb) during the setup time (LbAt).
- For example, if the LbAt is set at 100 seconds, while the LbAb is set at 10°C, an alarm signal will go off due to slight changes made to the temperature that are not exceeding 10°C.

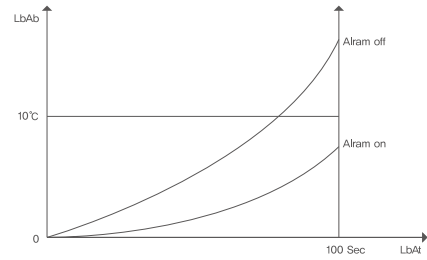

Factory reset

- This function initializes the controller. It is useful for cases when unable to pinpoint which parameters were changed. Use this function to initialize all parameters, and to restart from the beginning.
- Go to the password mode. Press the **SET** button with the symbol '0202' to revert changes made to the parameter group 3. The letters 'd1-e' will appear at the PV window. Press the **SET** button once more, and 'rESE' will be displayed at the 'PV' window.
- Change '0' to 'f' at the 'SV' window in order to activate the initialization function.
- Once the initialization function is activated, go to the startup screen and press the **▲▼** buttons at the same time for more than three seconds until the screen has changed several times, and then the parameters are initialized.
- The parameters can be initialized only when the setup value of the 'rESE' of the parameter group 2 is at 'f'. Such initialization will not be possible while the value is set at '0'.

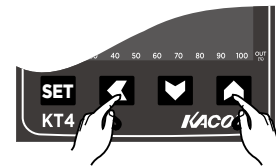

Manual control (Run/stop)

- Enter '0202' using the buttons at the password mode. Press the **SET** button to go to the parameter group 3. The letters 'd1-e' will be shown at the 'PV' window and '0' at the 'SV' window, respectively.
- To activate the RUN/STOP function, change the 'SV' value '0' to 'f', and then press the **SET** button to change the setup value.
- Once the function is activated, return to the startup screen, and then press the **▼** button for more than 3 seconds to set the function-stop.
- To relieve the function-stop, press the **▲** button for more than 3 seconds.
- When the symbol 'd1-e' is changed to 'f', the conversion between 'RUN/STOP' function will be performed. However, if 'd1-e' is changed to '0', the conversion between 'RUN/STOP' will not be performed.

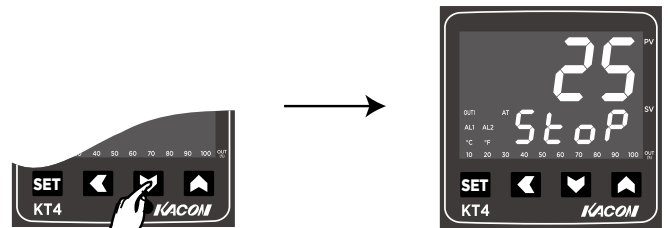

Error display

- OHMO** : This function indicates that the temperature sensors are not properly connected.
- OLLO** : This function indicates that the temperature sensors are connected; however, its temperature sensor setup is inaccurate. (Example: The case in which the thermo-coupler is actually connected, and the temperature sensor is set at 'PT'.)

Applied Terminals

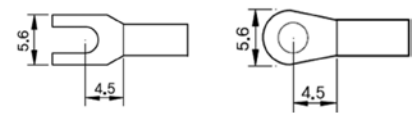

Installation Method

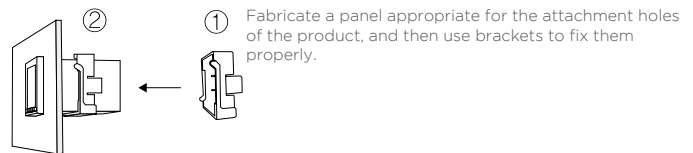

KACON

Industrial controls & Automation

#150-55 KAJIWA, SEO-GU, INCHEON, REPUBLIC OF SOUTH KOREA

T 82.32.575.4036-41 F 82.32.576.9300

www.kacon.co.kr

affiliated companies my planet K O T A X